

## Instructions for a play

1. Decide what you/your group would like to explore in your play. You can choose from the following ideas or pick your own:

- How would a local business owner respond to working with an artist?
- What have the young people in this town got to offer?
- How might we unlock the creativity of people who don't consider themselves creative?
- What would happen if we put a musician on a building site?

2. Choose a backdrop and insert into theatre.

3. Choose two or three characters from the following list, or make up your own:

- Shopkeeper
- Local councillor
- 7 year old boy
- 15 year old girl
- Construction worker
- Teacher
- Pub landlord
- Visual artist
- Tourist
- Lorry driver
- Musician
- Single parent
- Office worker

Use the cut-out character shapes and whatever material/photos/images you have to make your characters come to life.

4. Get to know them by asking each the following questions:

- What do you want most in the world?
- What is your greatest fear?
- What achievement you are most proud of?
- If you were given an unexpected afternoon off, what would you do?

5. Place your characters into the theatre space. Choose which one will speak first. You can pick from the following lines, or script your own:

- "I've always wanted to ..."
- "The thing is I'm not an arty person..."
- "I've had an idea..."
- "I haven't got time for this..."
- "Have you heard about..."

6. Let the scene develop. Trust your instinct. See what emerges from the dialogue.

7. Try starting again from the beginning and doing things differently.

# Creative Places Theatre

## Instructions

Print out designs on A4 paper. Stick these to thin cardboard and colour in before building together.

side panels

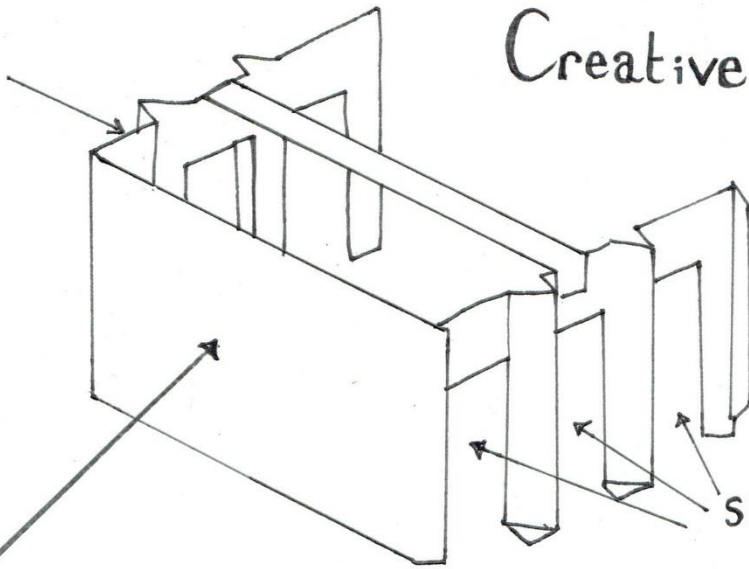

Slots for backdrops scenery and characters

Back of the Theatre, wings, & side panels  
(this can also be constructed with a small cardboard box)

## Theatre Front

Cut out front

Cut along the lines shown in bold on both left and right sides

Score along the dotted lines. These panels will angle inwards towards the stage.

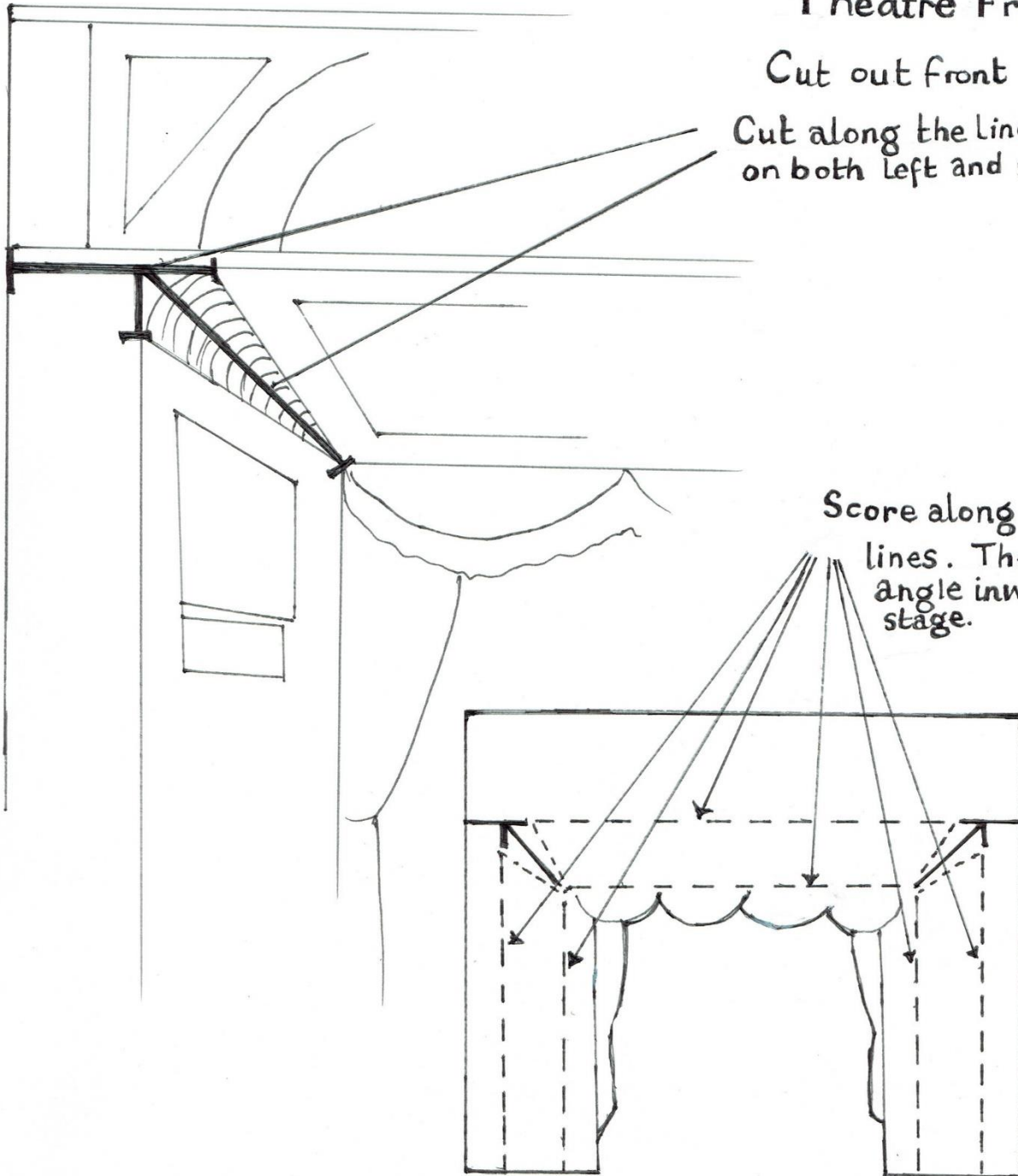

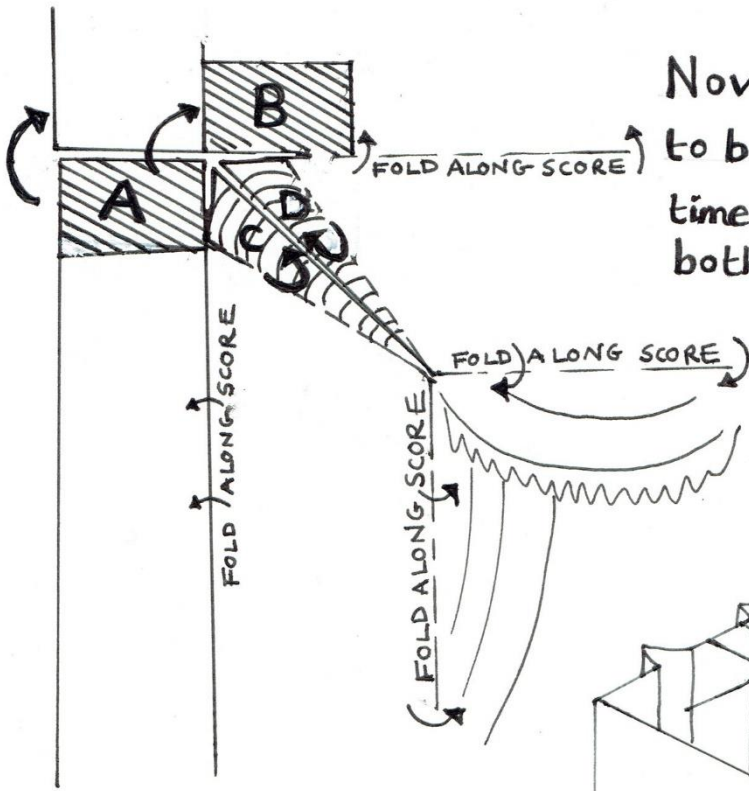

Now glue the front area 'A' to behind area 'B'. At the same time glue 'C' to 'D'. Do this on both sides

Now glue the front to the back of the theatre, and join both to the stage.

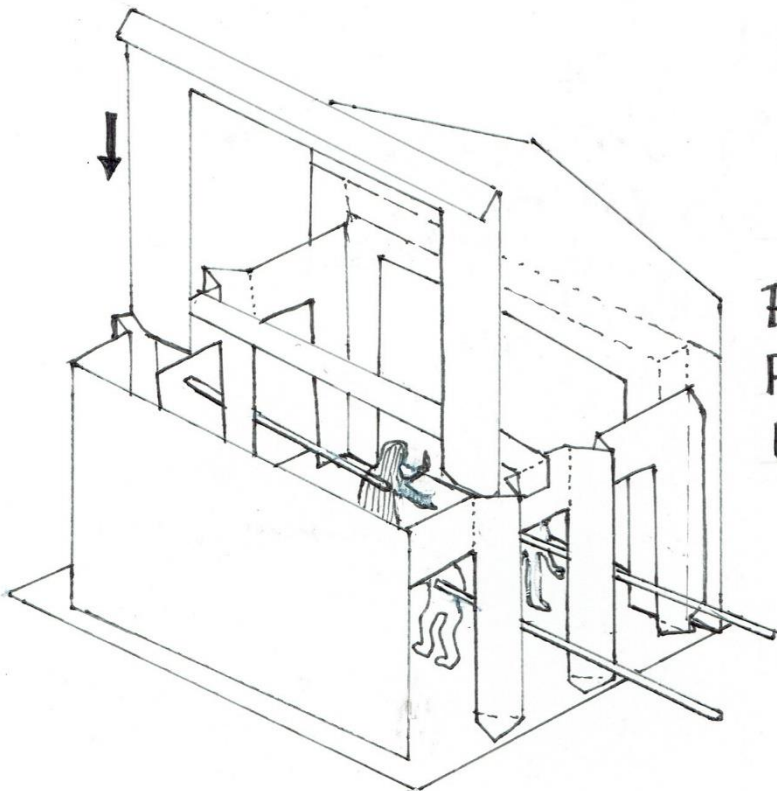
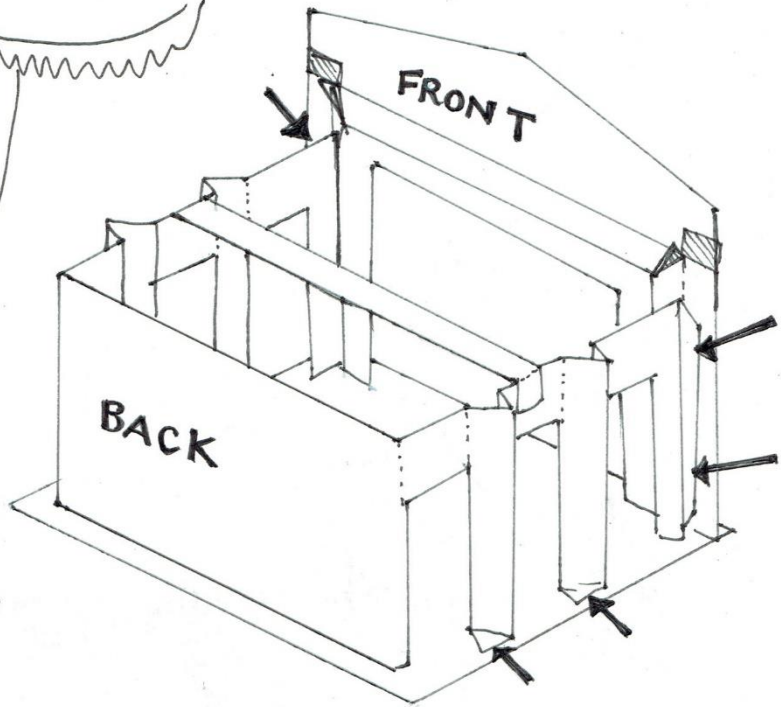

Showtime!

Pick your characters,  
Pick your script, and  
the play can begin.



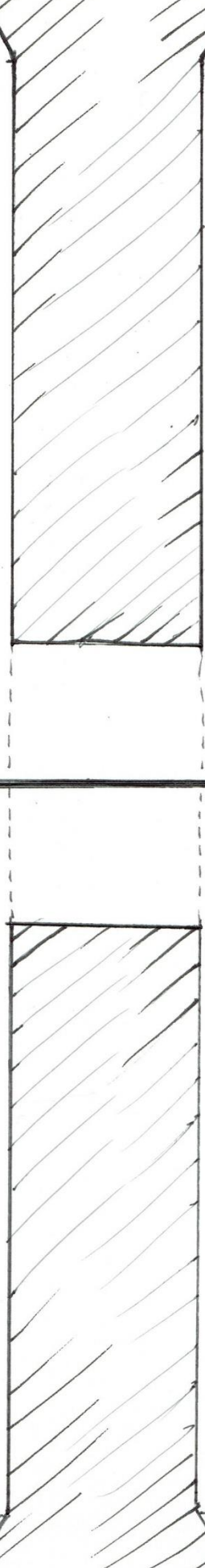
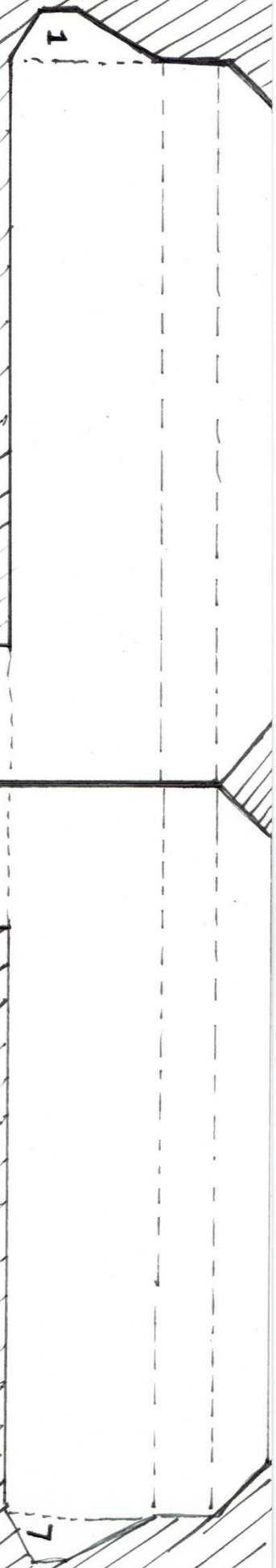

Theatre side panels  
(left)

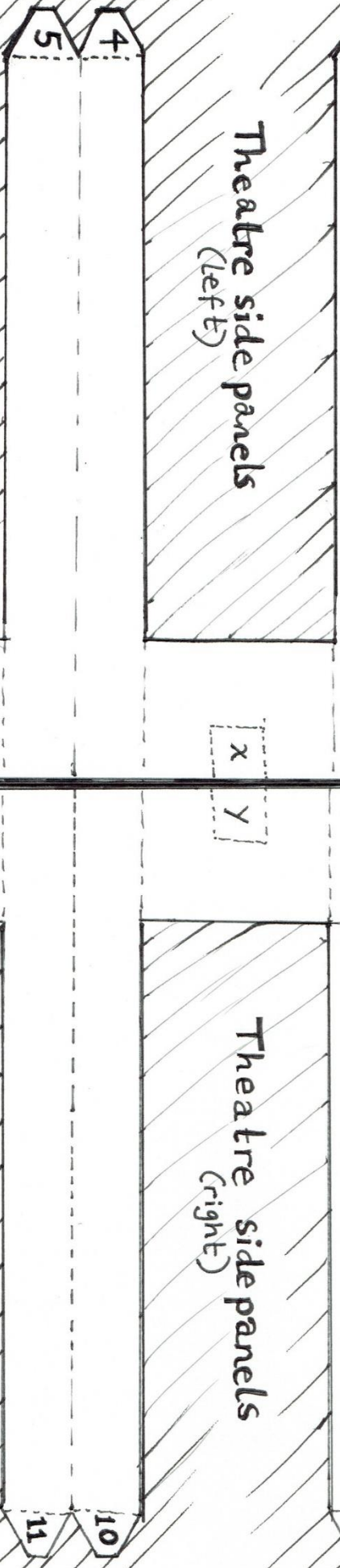

Theatre side panels  
(right)

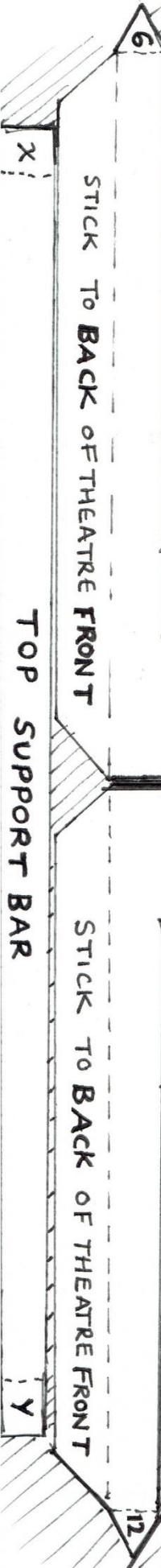
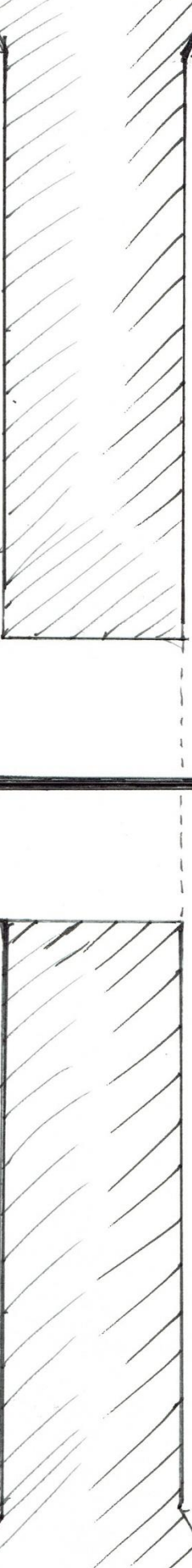

x  
y

STICK TO BACK OF THEATRE FRONT

STICK TO BACK OF THEATRE FRONT

TOP SUPPORT BAR

x

y



CREATIVE PLACES THEATRE  
PRESENTS

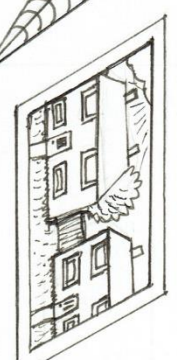

BUILD YOUR OWN THEATRE

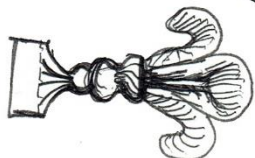
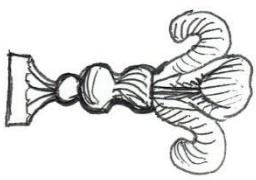
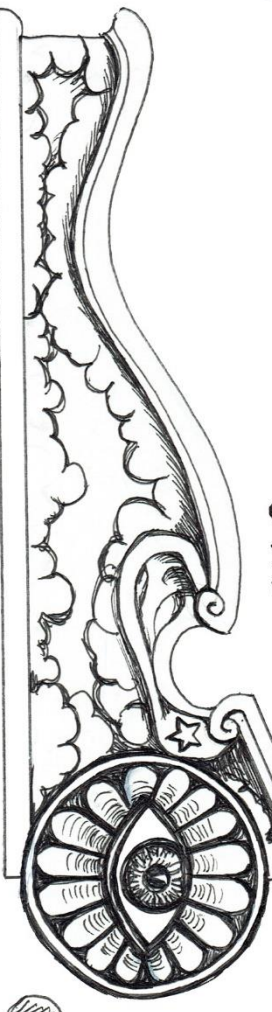

STICK EYE  
HERE

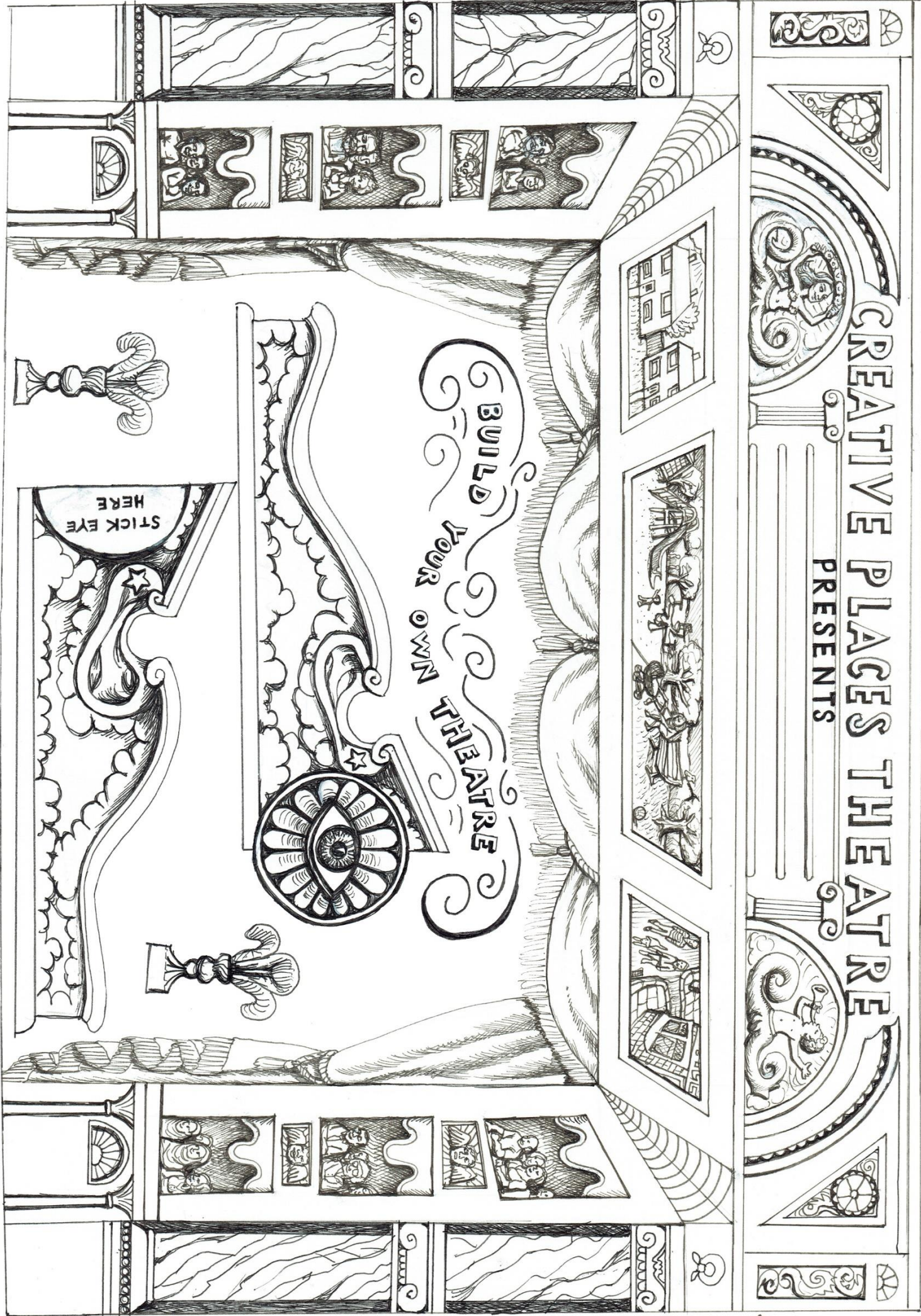







A LIVING ROOM



PUBLIC PARK





# HOSPITAL WAITING AREA

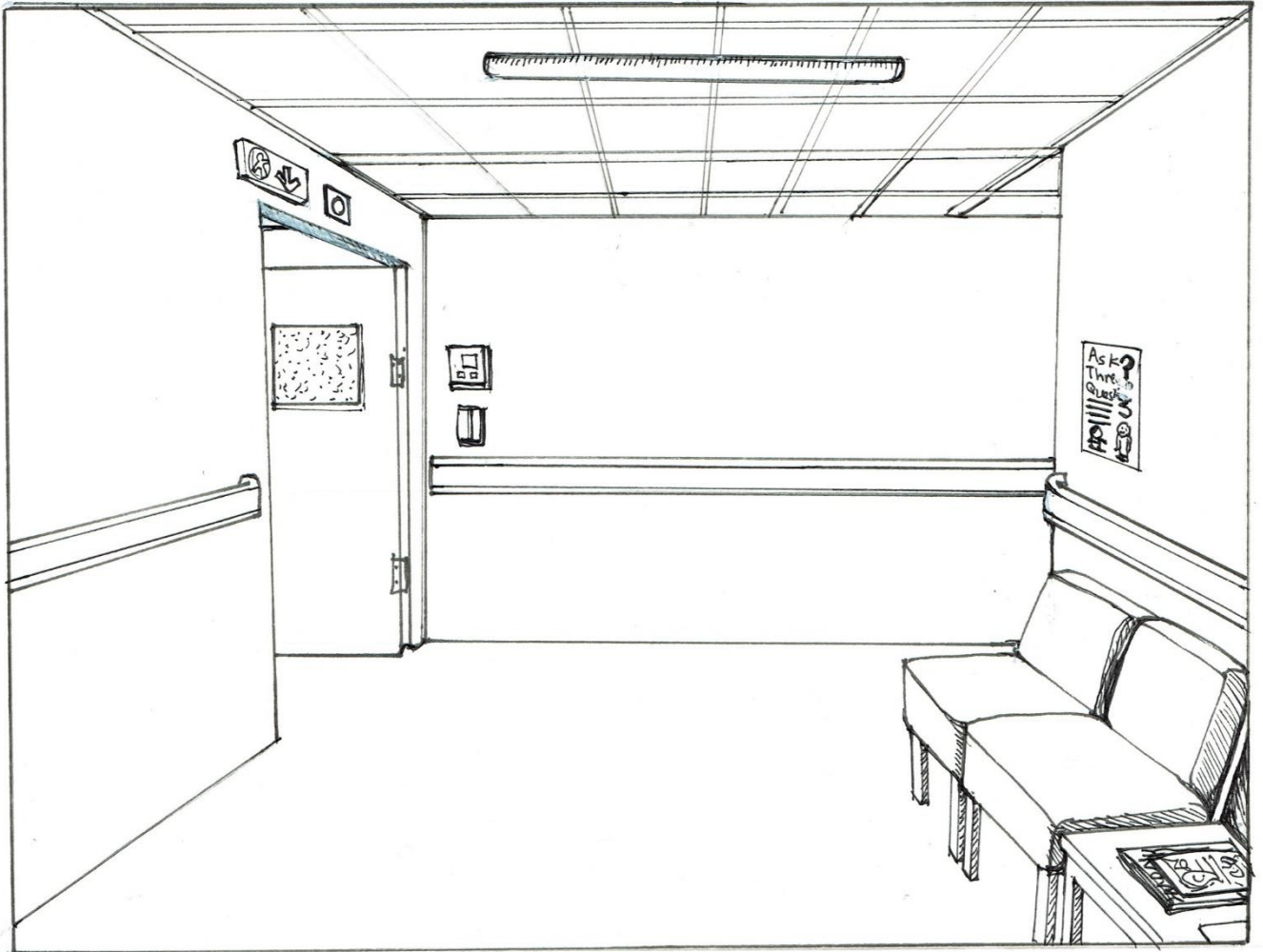

# PUBLIC LIBRARY

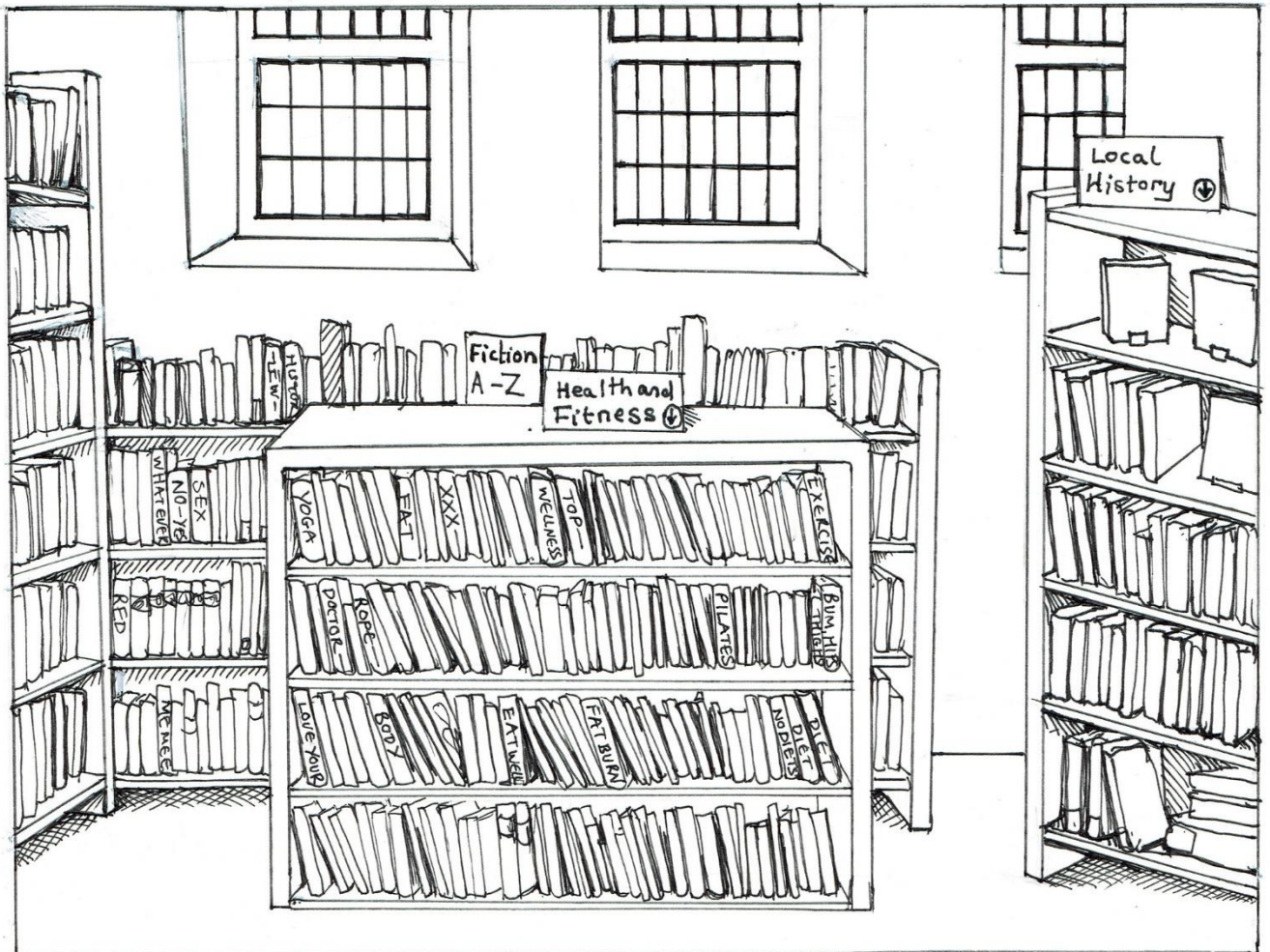



## A PUB

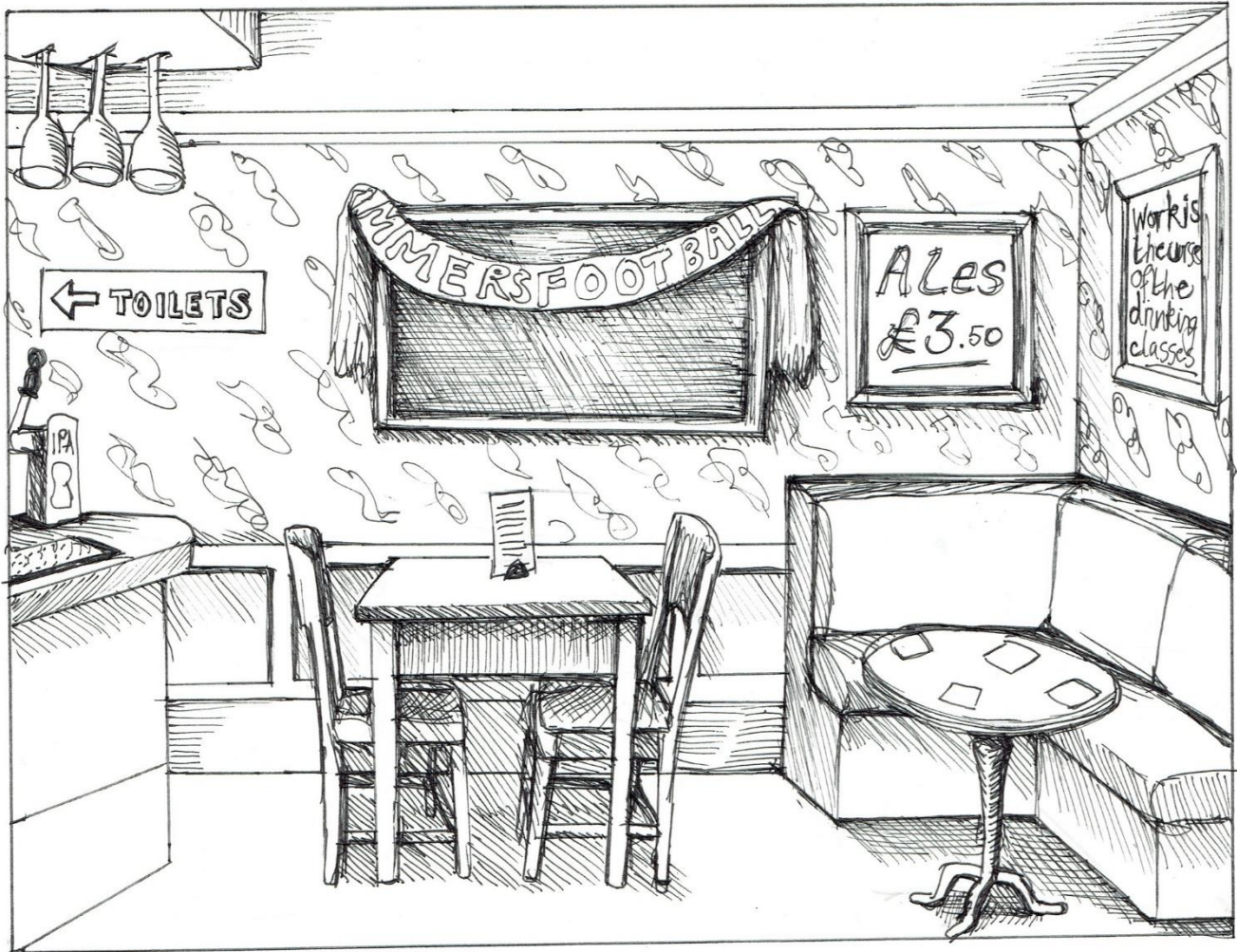

## A COMMUNITY HALL

